

Connecting radios all over the world

**When to use a RadioServer and
when to use a NetworkRepeater
- or a Mimer Multi X-Bridge (MxB)**

Mimer SoftRadio



When connecting over the Internet with TCP the Network Interface itself only handles one Dispatcher.

This can be expanded by the use of a **RadioServer**, a **NetworkRepeater** or a **Multi X-Bridge** or in some cases by using several servers.



On the other hand, in a local LAN-system where UDP is used between Dispatchers and NetworkInterfaces, 99 Dispatchers can share the same radio.
No server needed!

Mimer SoftRadio



Connection can be done over almost any type of IP:

- Fixed connections over copper or fibre.
- Cordless over WLAN or Microwave.
- Cellular over 4G or 5G.
- Satellite over Starlink, Iridium, Inmarsat etc.

High orbit satellites requires the use of the special Radio Server with satellite mode.

Low orbit satellites like “Starlink” does not need any special equipment. It works about the same as a 4G connection.

Mimer SoftRadio



In the examples we have used green lines to illustrate UDP-connections and red lines to illustrate TCP-connections.

There is also a special case at the end with a satellite connection.

Please note that there are many more setups possible, so please ask when uncertain.



UDP Broadcast

Used in a local LAN subnet

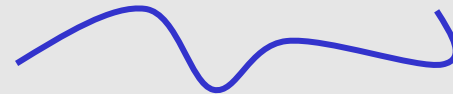

UDP Unicast

(only used in high orbit satellite connections)

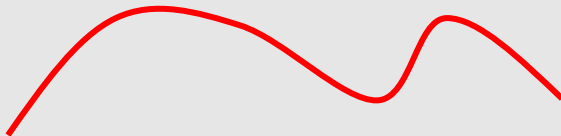

TCP

Used in remote connections

Remote Dispatcher over the Internet

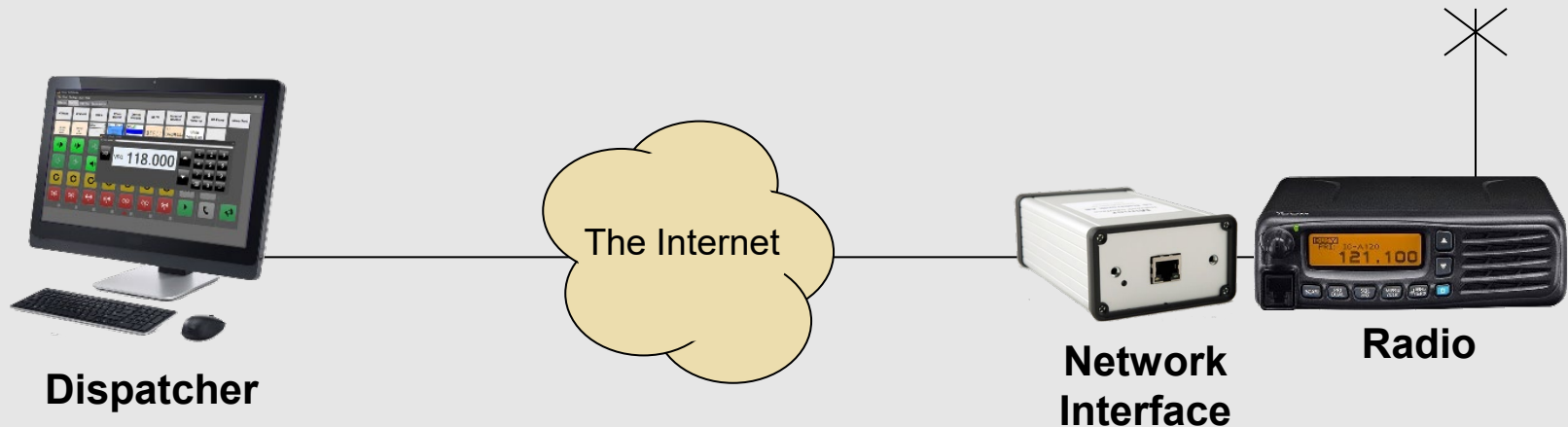

One radio can be connected via TCP through the Internet.

The Network Interface handles one connection of this type at any given moment.

Remote Dispatcher over the Internet

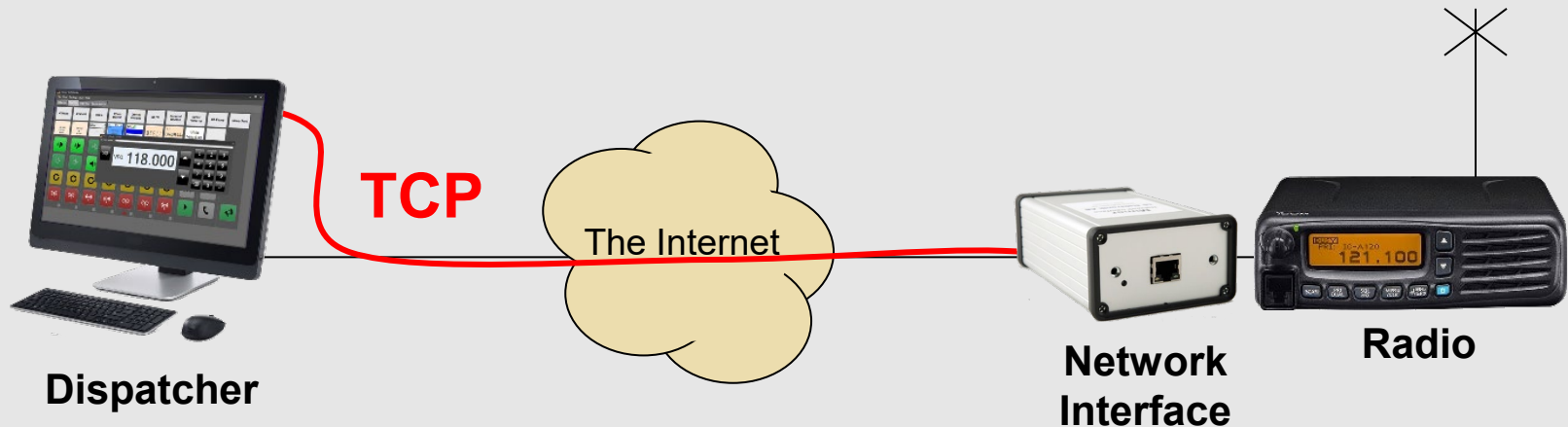

The Dispatcher PC connects to the Network Interface via TCP over the Internet.

Remote Dispatcher over the Internet

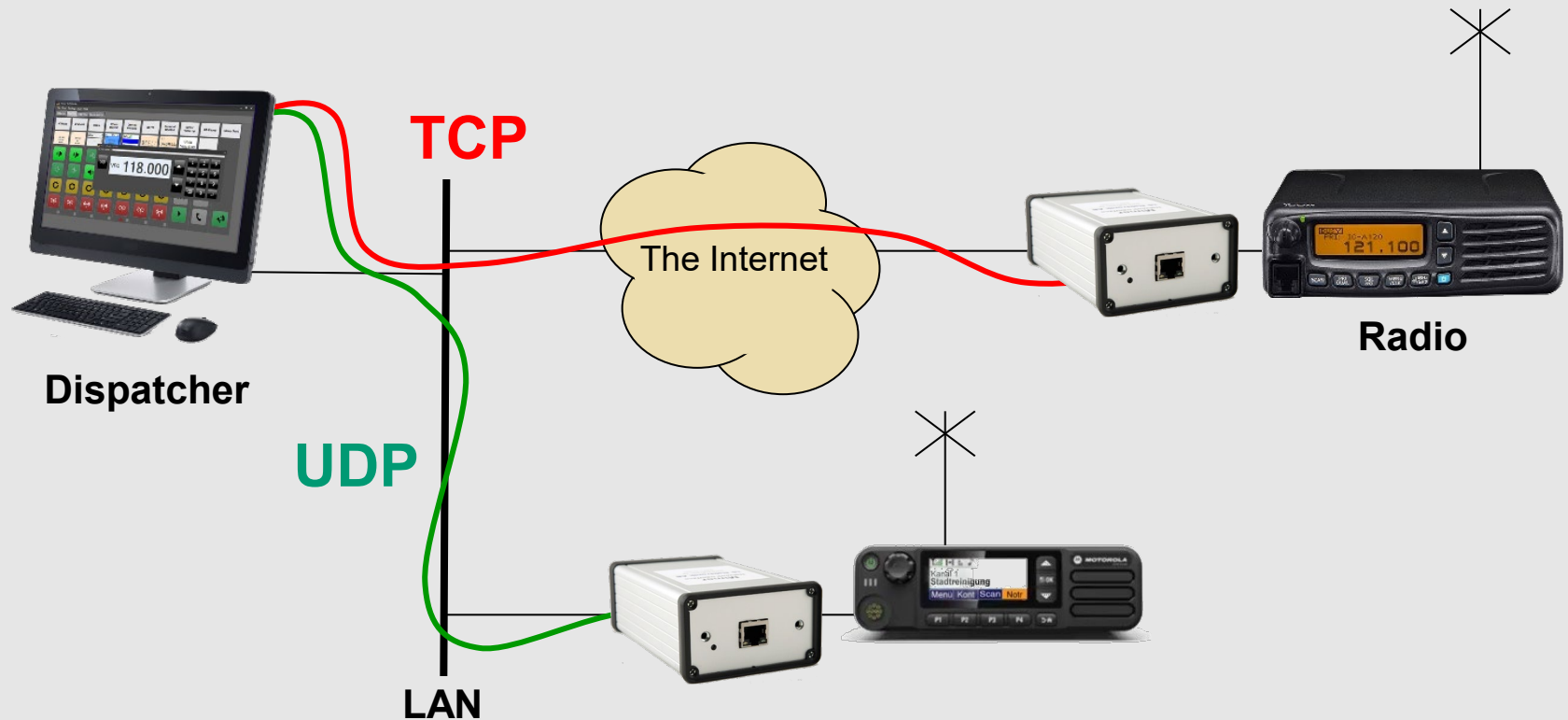

The Dispatcher PC connects to the Network Interface via TCP over the Internet.
At the same time, one or many radios can be connected locally via UDP.

Remote Dispatcher over the Internet

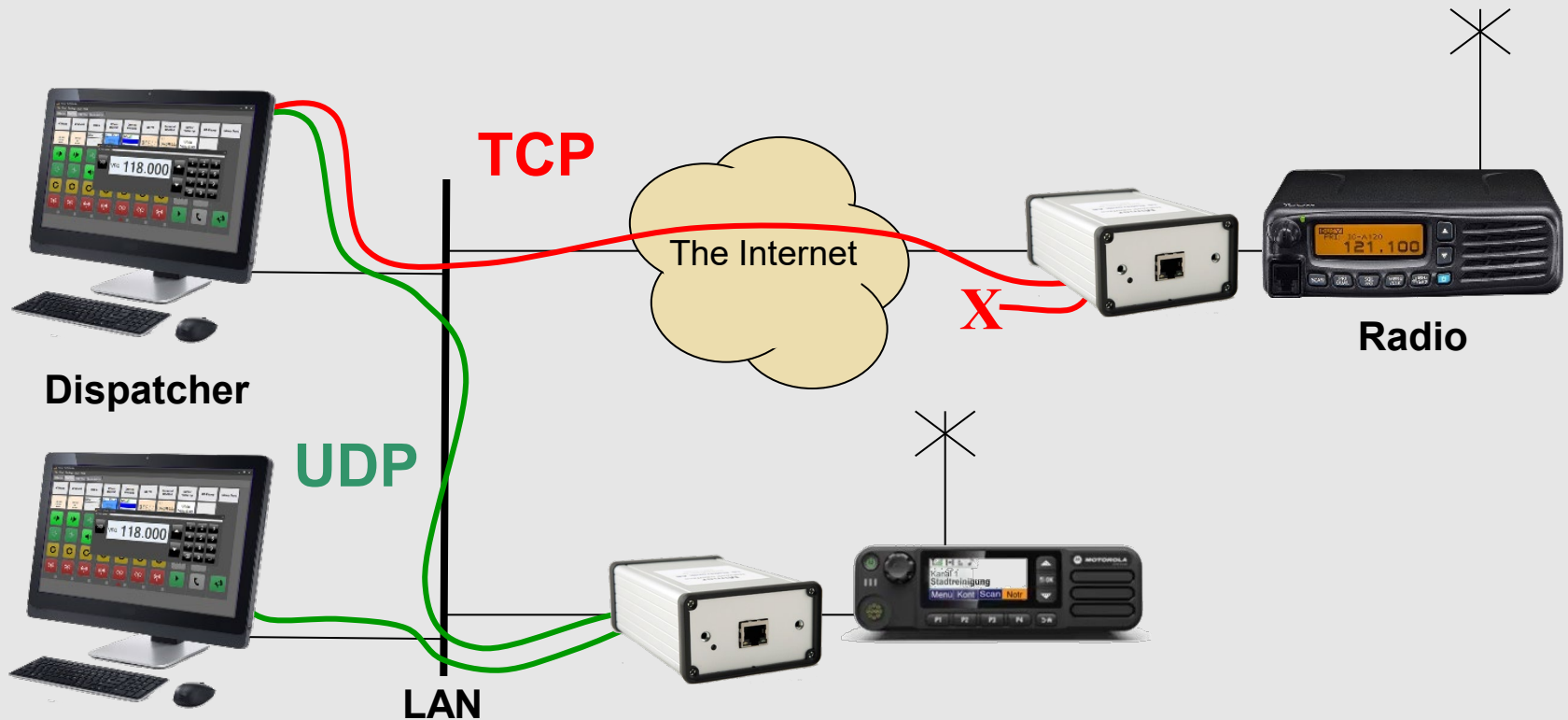

A second Dispatcher can connect to the local radio through UDP.
But not to the remote radio since the Network Interface only handles one TCP connection.

Several Dispatchers over the Internet

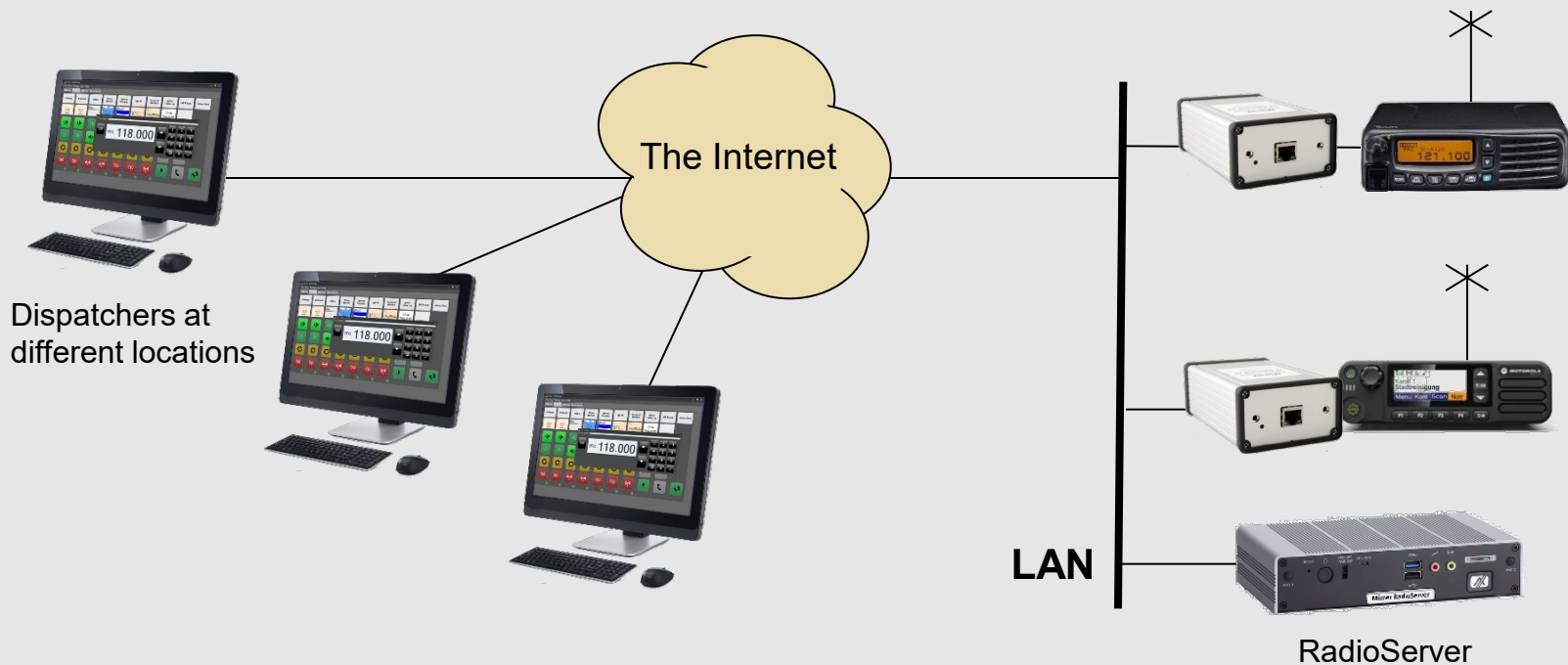

With the help of a Mimer RadioServer many users can connect simultaneously from different locations to each radio.
The RadioServer also services many radios at the same remote site.

Several Dispatchers over the Internet

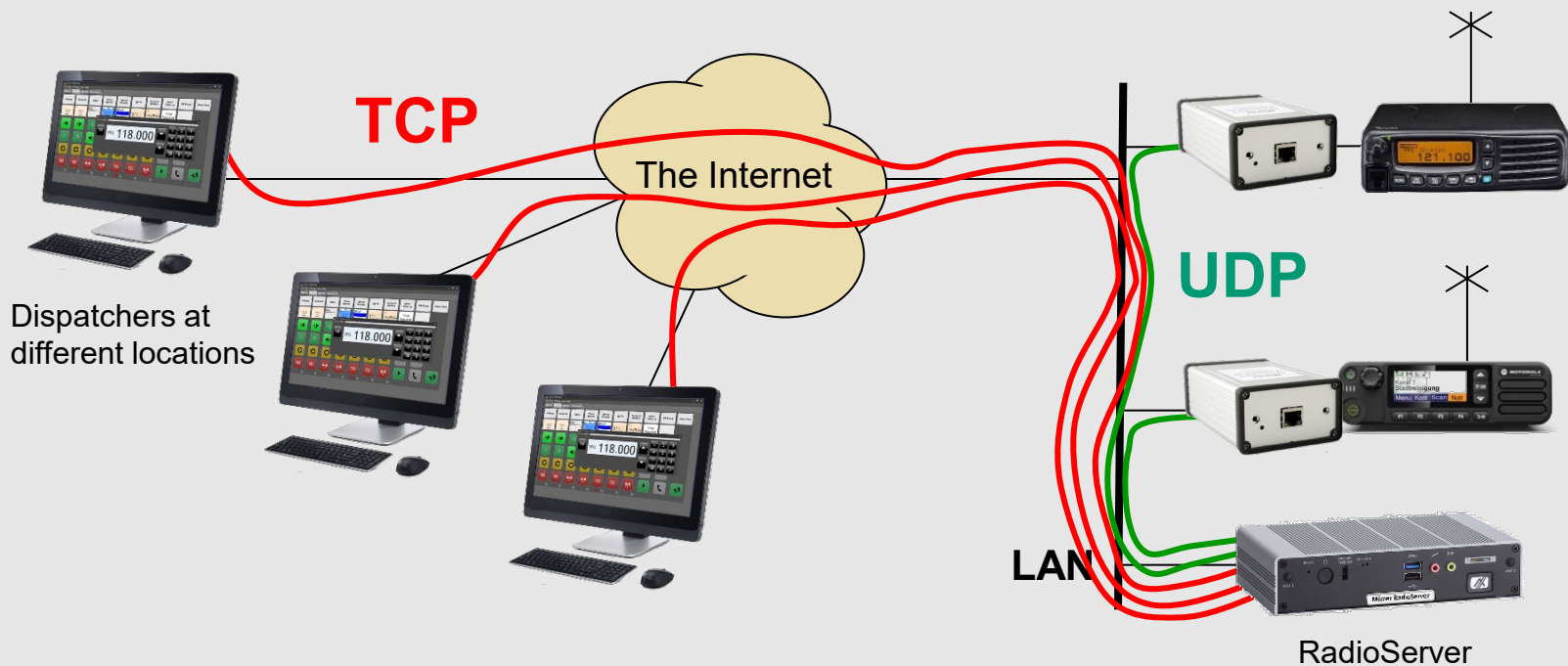

The RadioServer connect to the local Network Interfaces via UDP.
The Dispatcher PC's then connect to the RadioServer via TCP over the Internet.

Several Dispatchers over the Internet

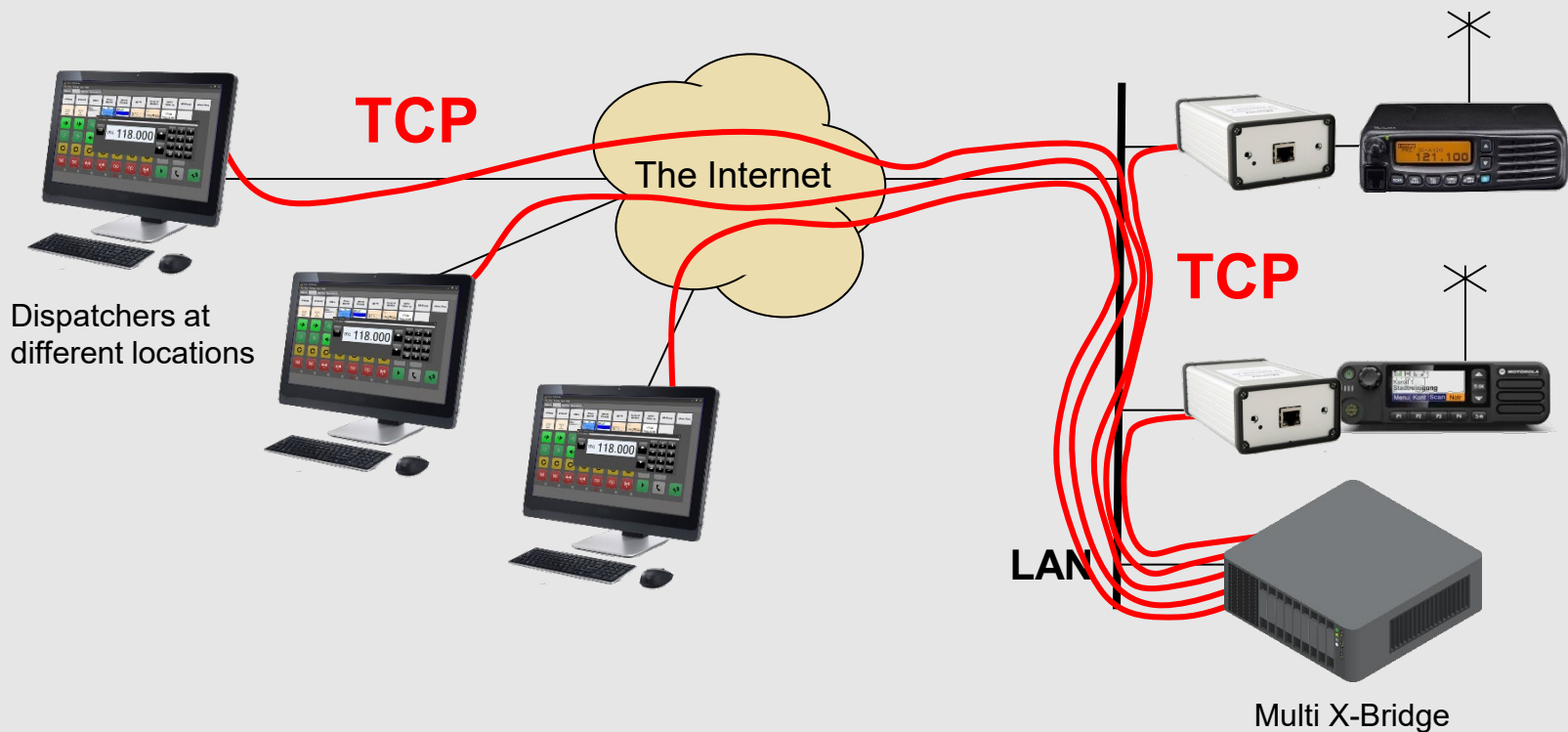

You can also use the Multi X-Bridge, then all connections are TCP

Several Dispatchers and radios over the Internet

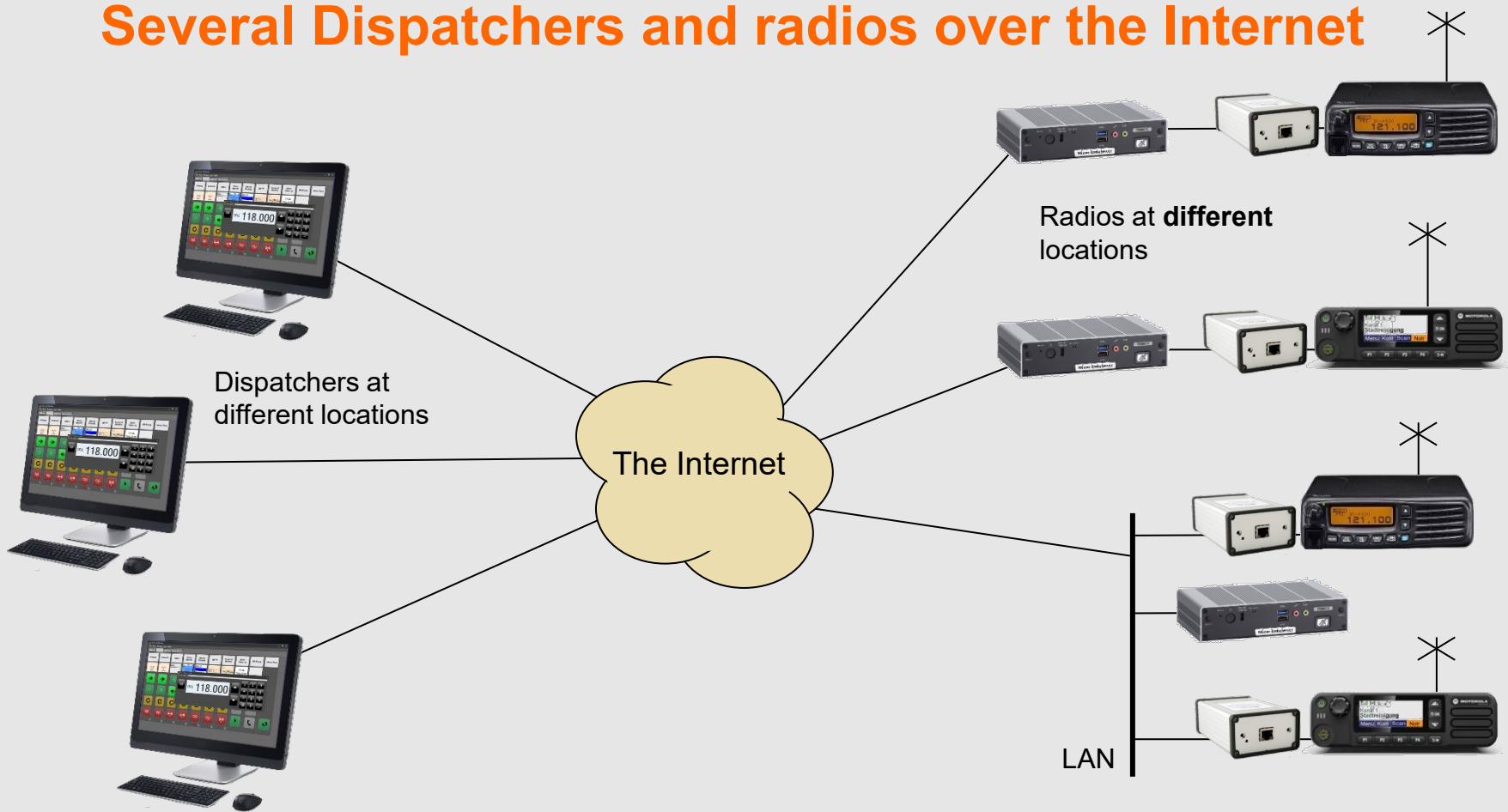

In a system where both radios and dispatchers are spread out and using the Internet for access. One RadioServer is needed at each radio site. Connections are made in the same manner as in the example above.

One Dispatch Central and several radio sites spread out

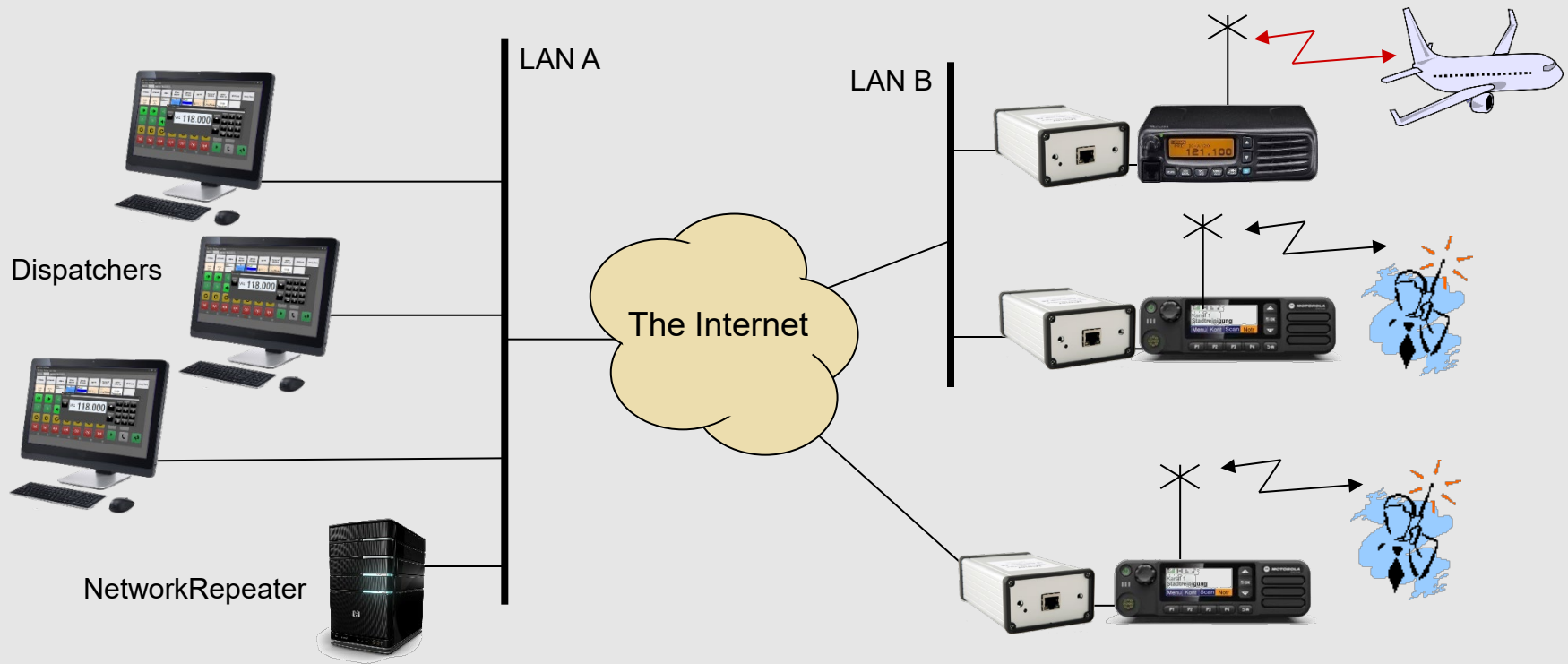

When you have one Dispatch Central with several operators that need to connect to several radios, at different locations, over the Internet, the NetworkRepeater will do the TCP connection to each radio and each Dispatcher will connect locally via UDP to the NetworkRepeater. Compared to RadioServers you will save bandwidth over the Internet.

One Dispatch Central and several radio sites spread out

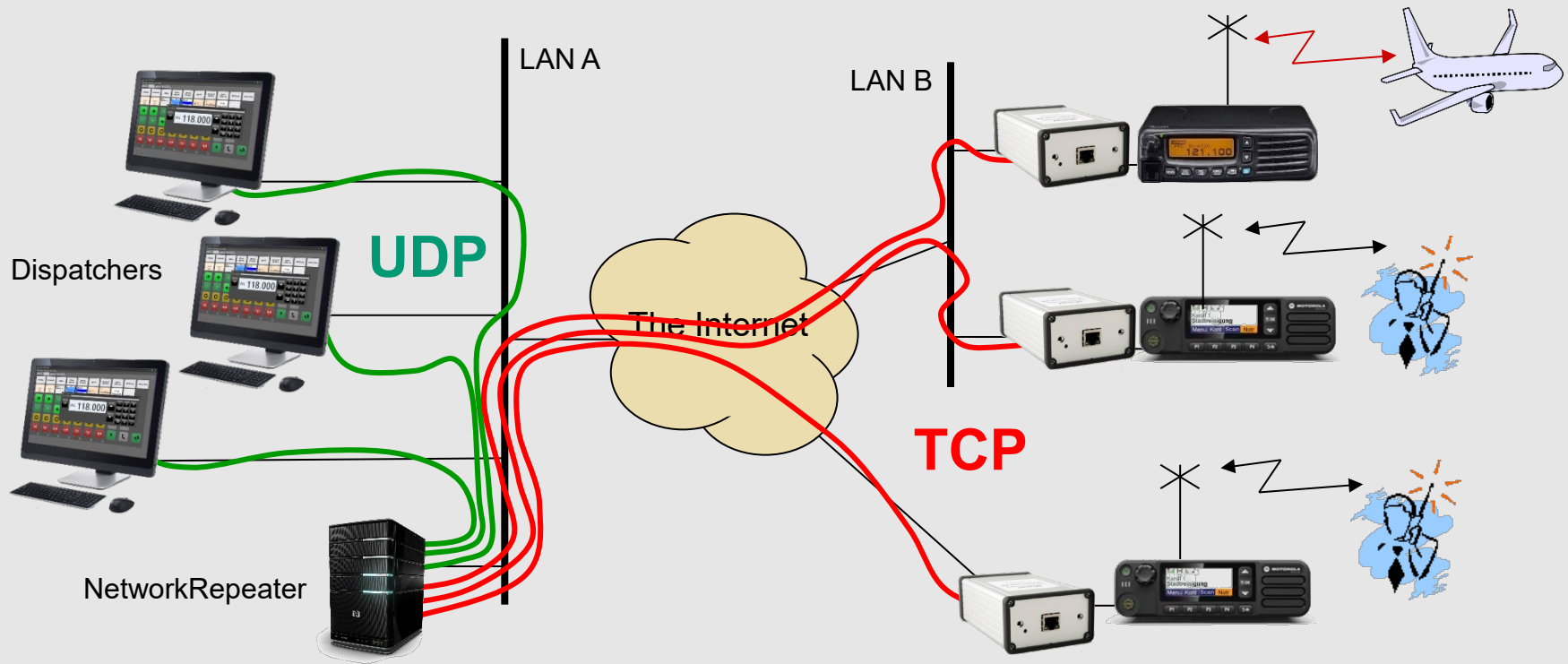

The NetworkRepeater connect to the Network Interfaces via TCP over the Internet.

The local Dispatchers then connect to NetworkRepeater via UDP.

One Dispatch Central and several radio sites spread out

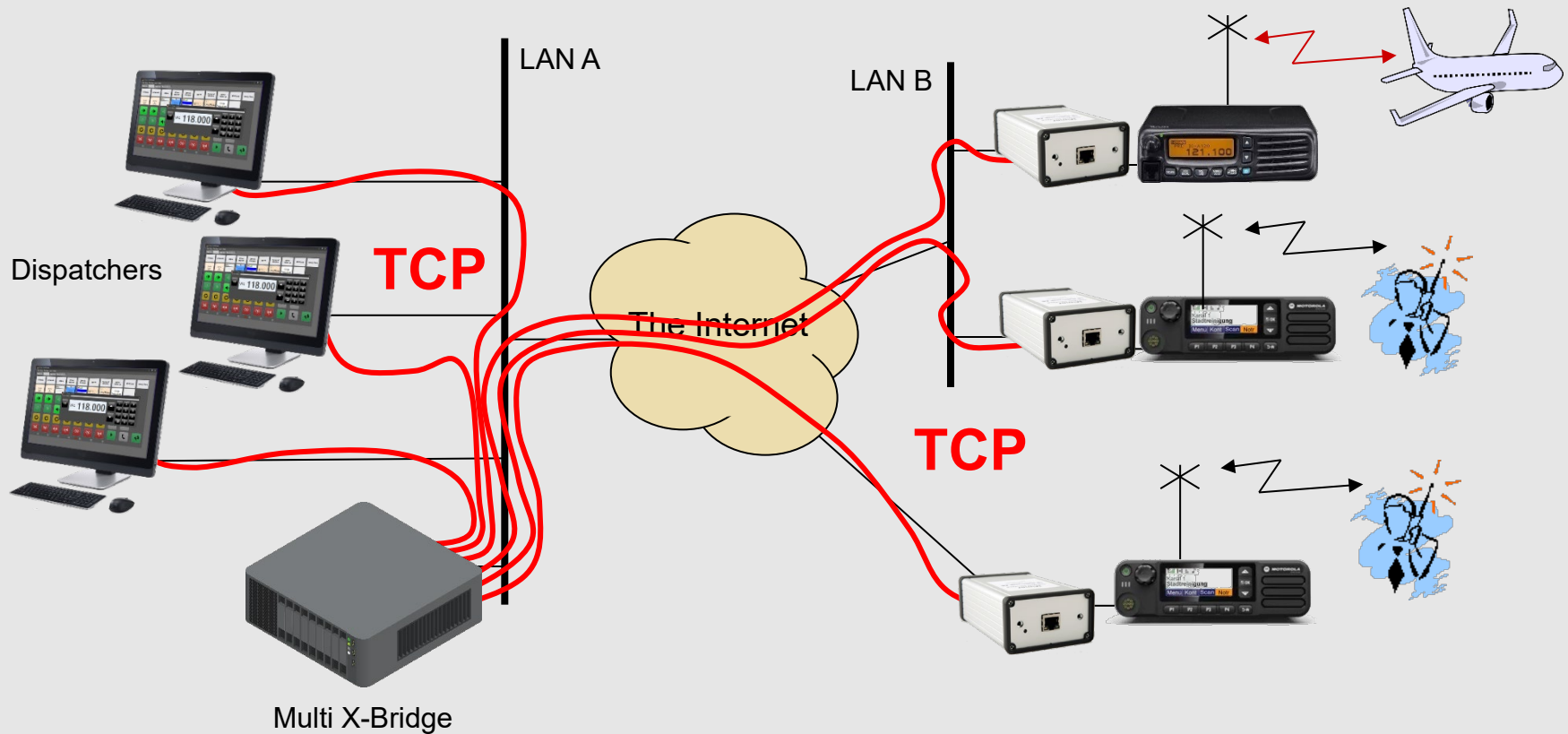

You can also use the Multi X-Bridge, then all connections are TCP

One Dispatch Central and several radio sites spread out, with VoiceLog

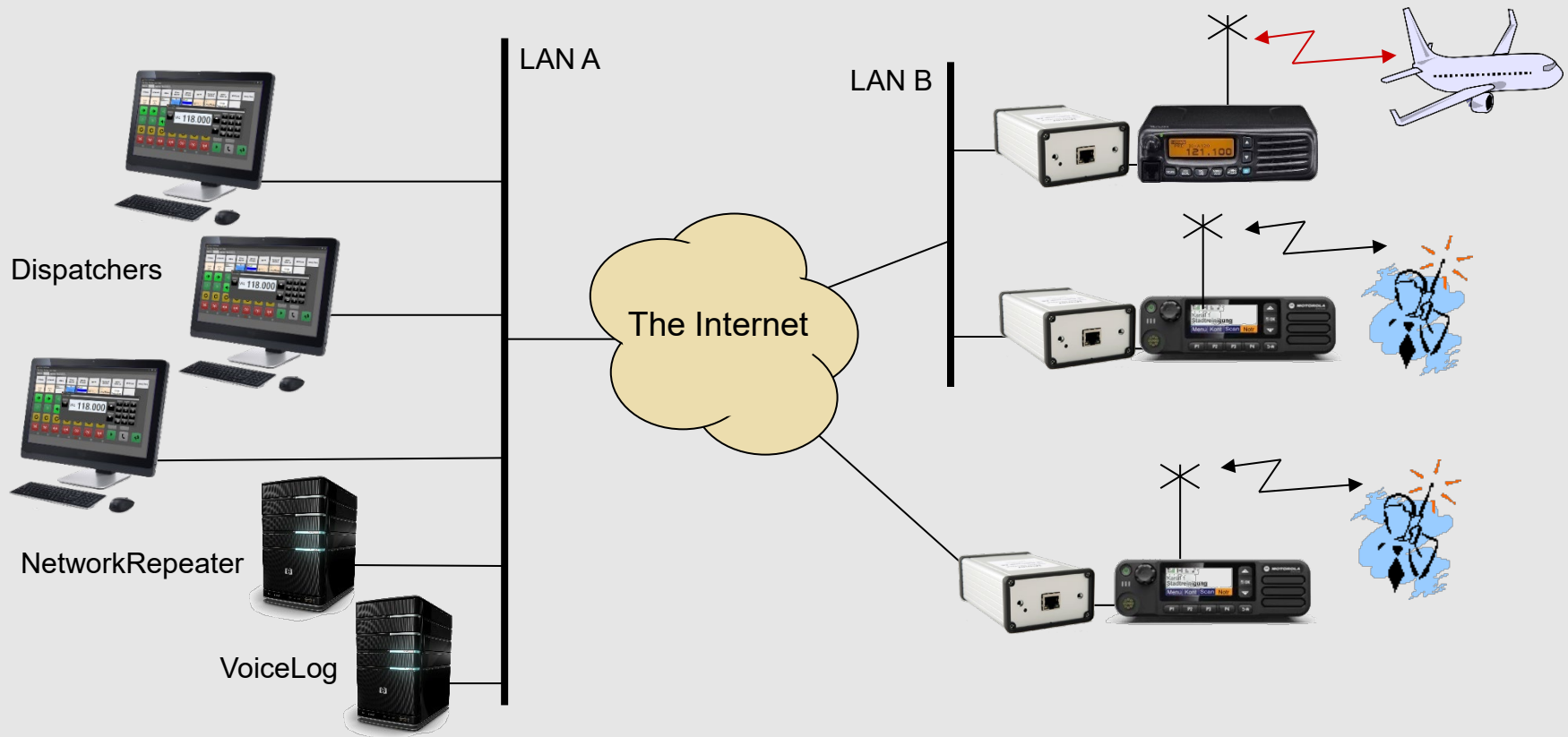

When you add a Mimer VoiceLog (for audio recording) to the system, this must be placed in the LAN where you have the NetworkRepeater or Multi X-Bridge. It will get its received radio audio from the NetworkRepeater as **UDP**. It can not connect directly to the Network Interfaces using TCP.

Remote control from several places of several radios

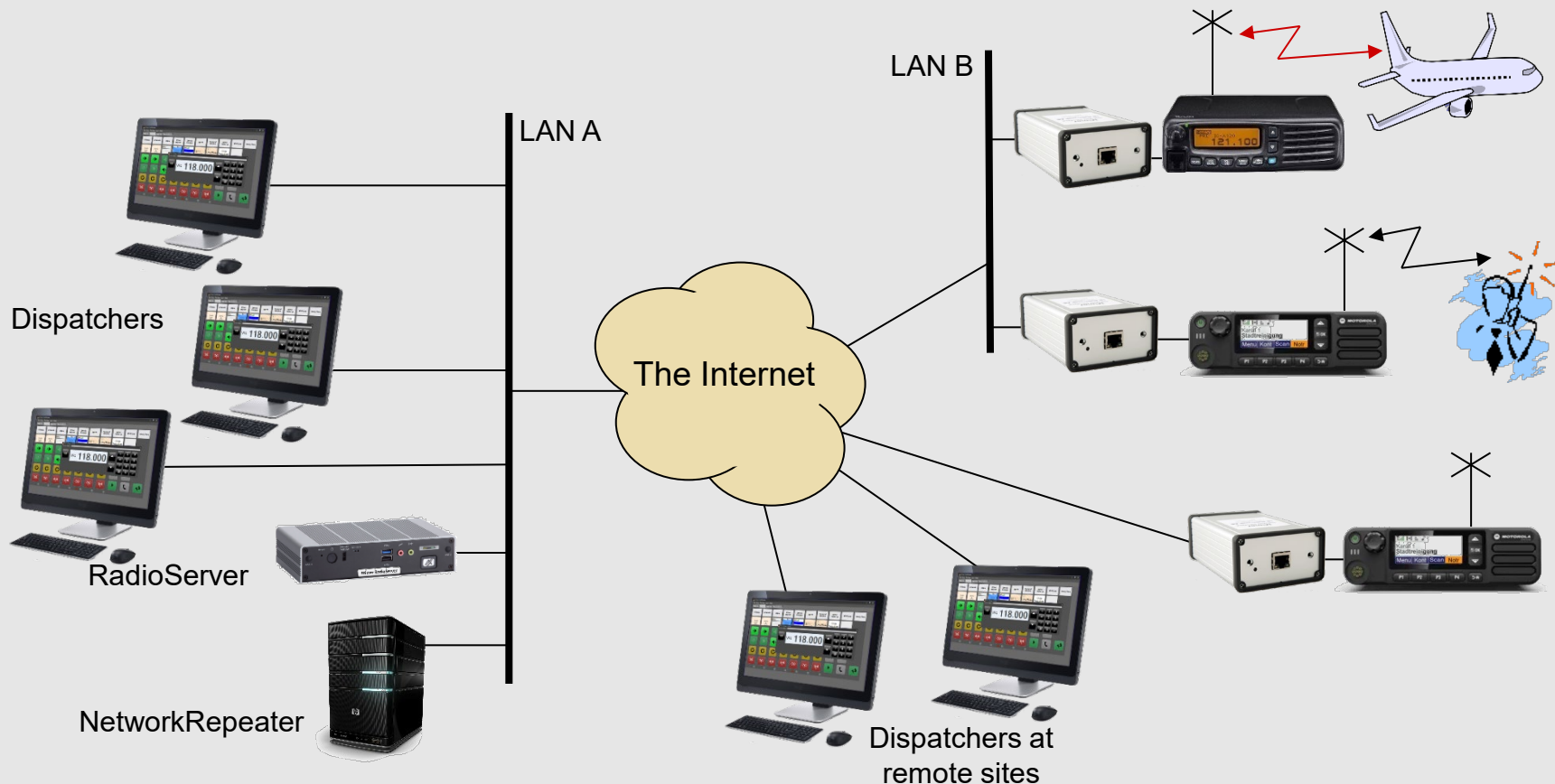

If you both have a Dispatch Central with many operators and you have other operators spread over the internet, working from home or a back up Dispatch Central. You will need both a RadioServer and a NetworkRepeater.

Remote control from several places of several radios

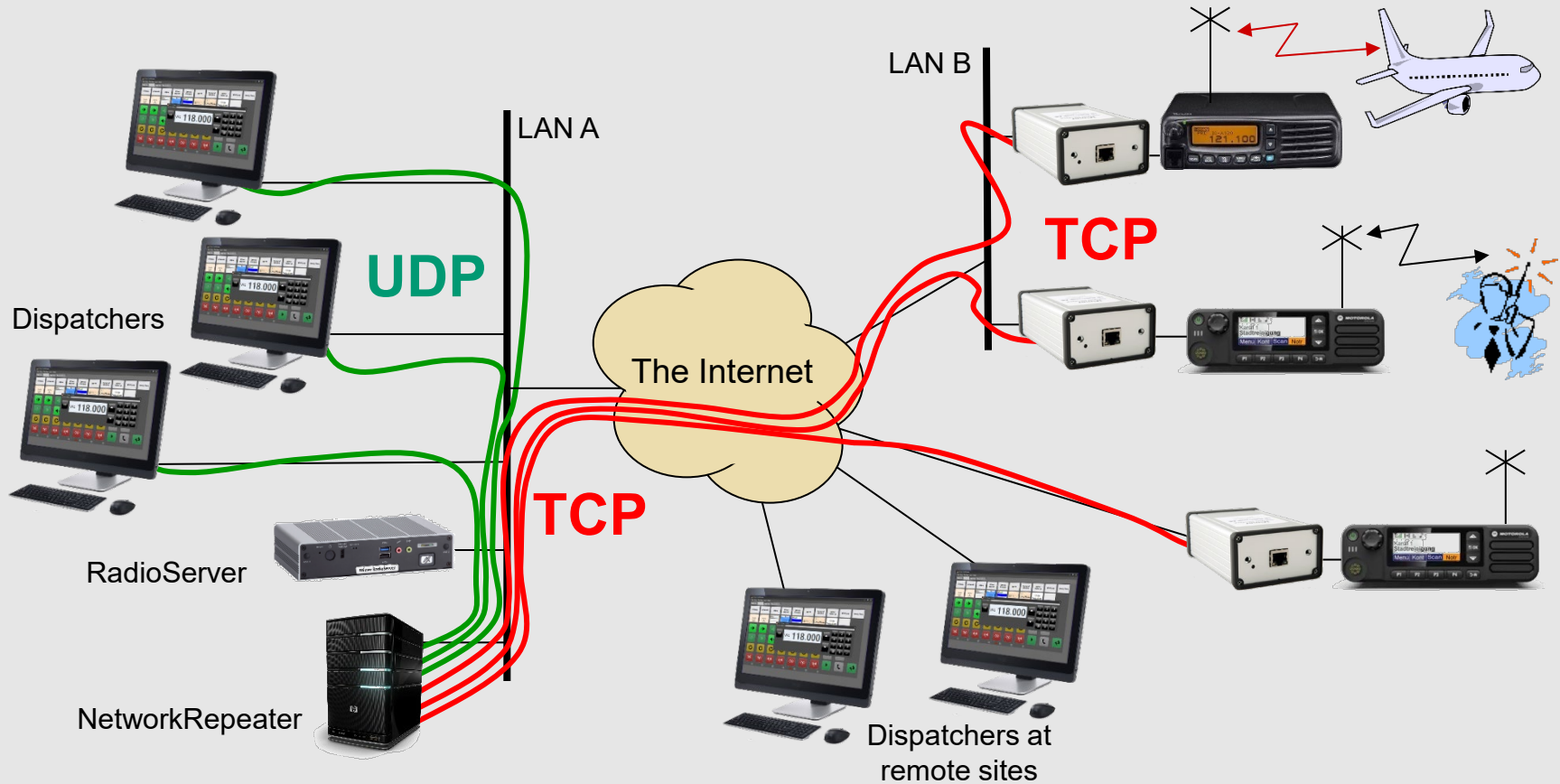

The NetworkRepeater connect to the Network Interfaces via TCP over the Internet.

The local Dispatchers then connect to NetworkRepeater via UDP.

Remote control from several places of several radios

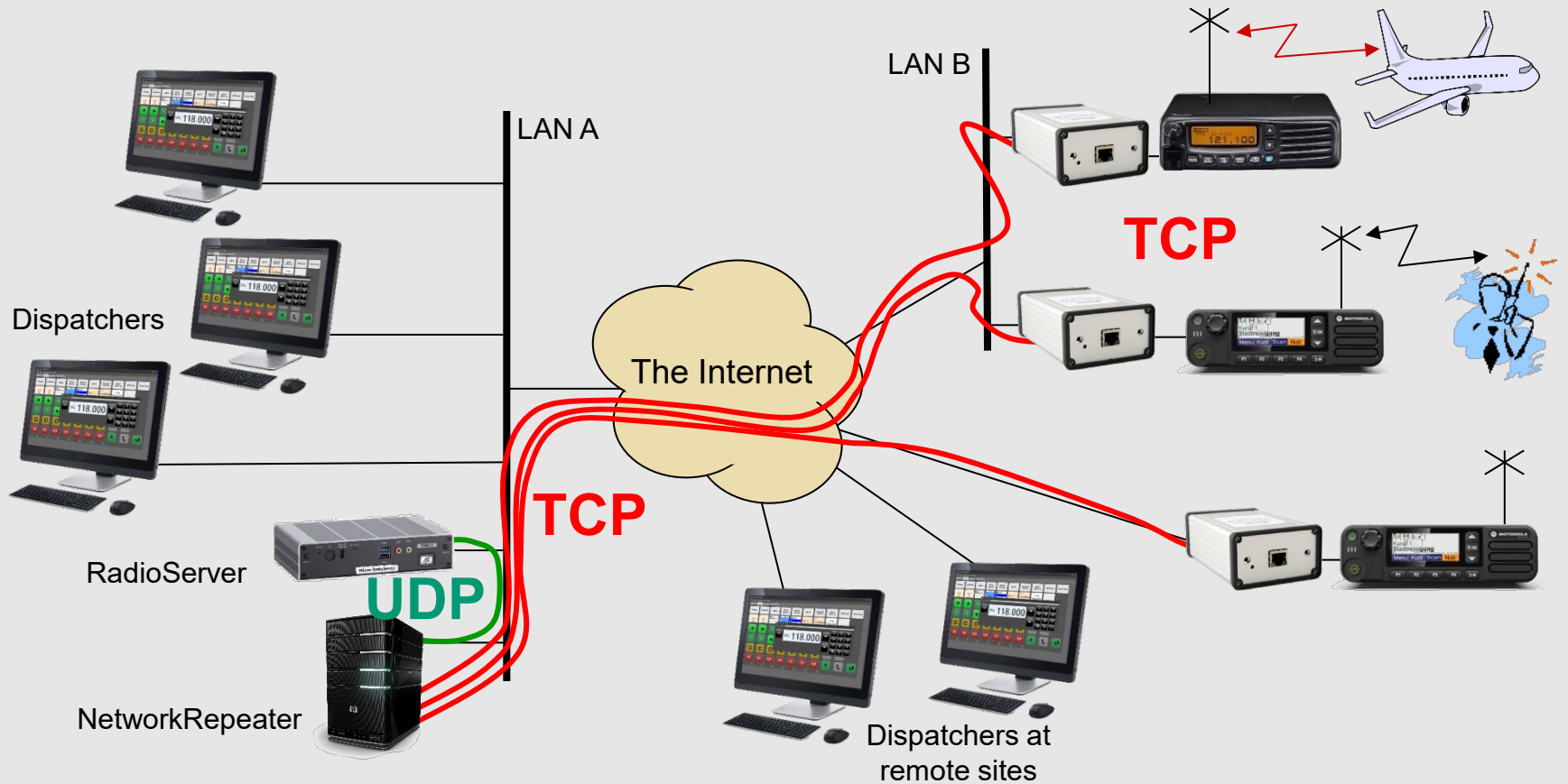

The RadioServer also connect to the NetworkRepeater via UDP.

Remote control from several places of several radios

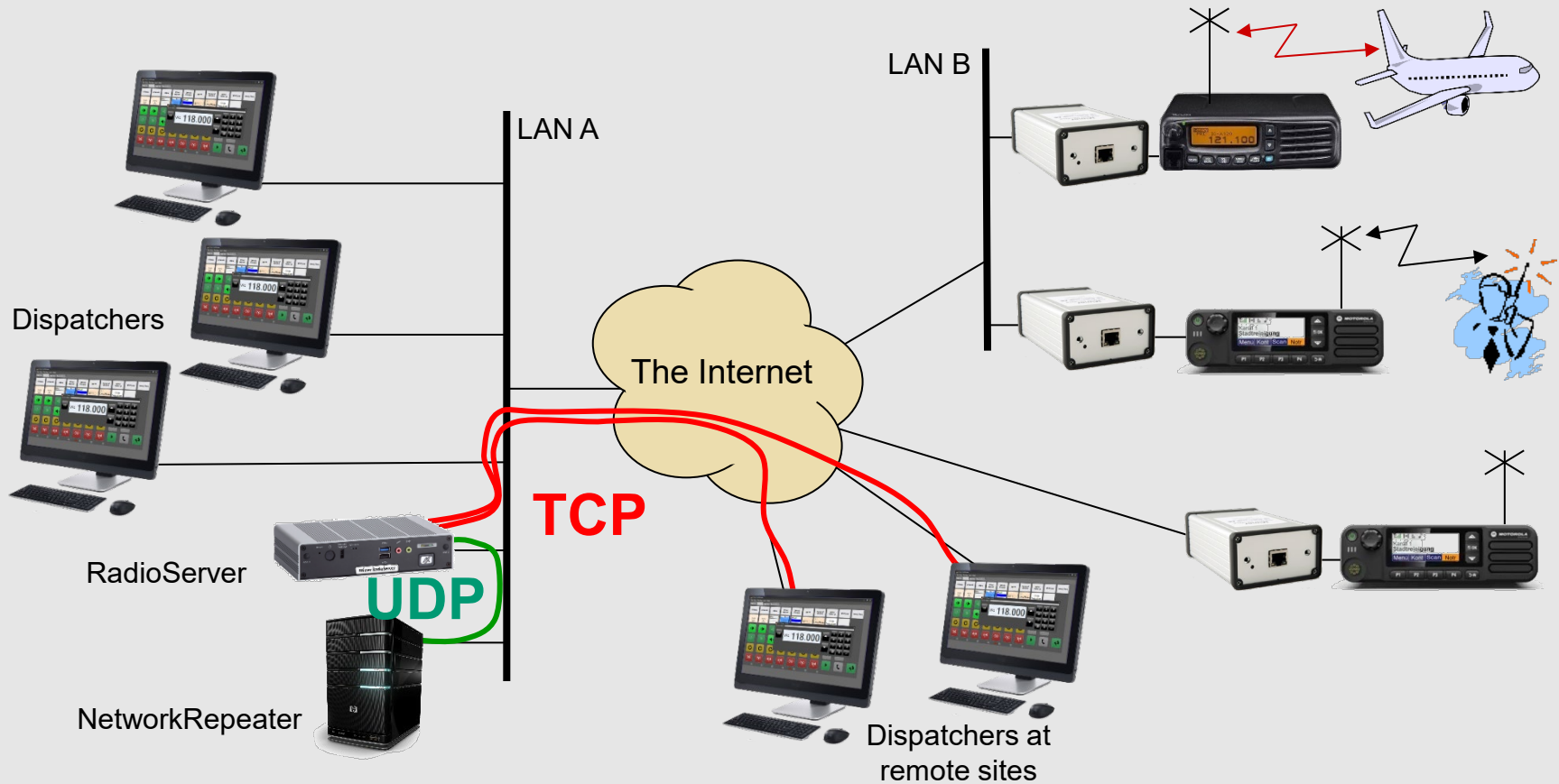

The RadioServer connect to the NetworkRepeater via UDP.
The remote Dispatchers then connect to the RadioServer via TCP over the Internet.

Remote control from several places of several radios

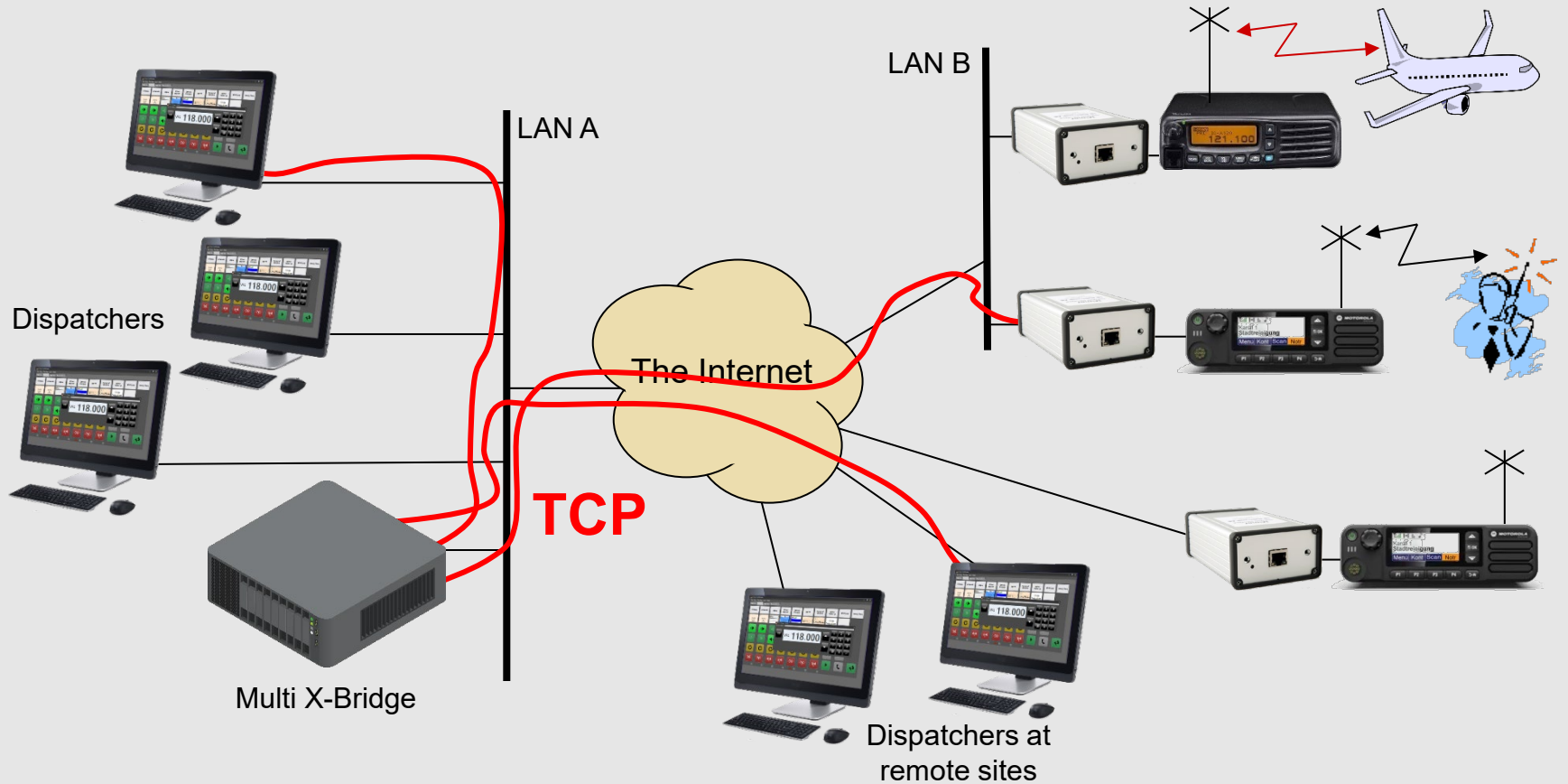

You can also use the Multi X-Bridge, then all connections are TCP

Remote control from several places of several radios

Alternative setup

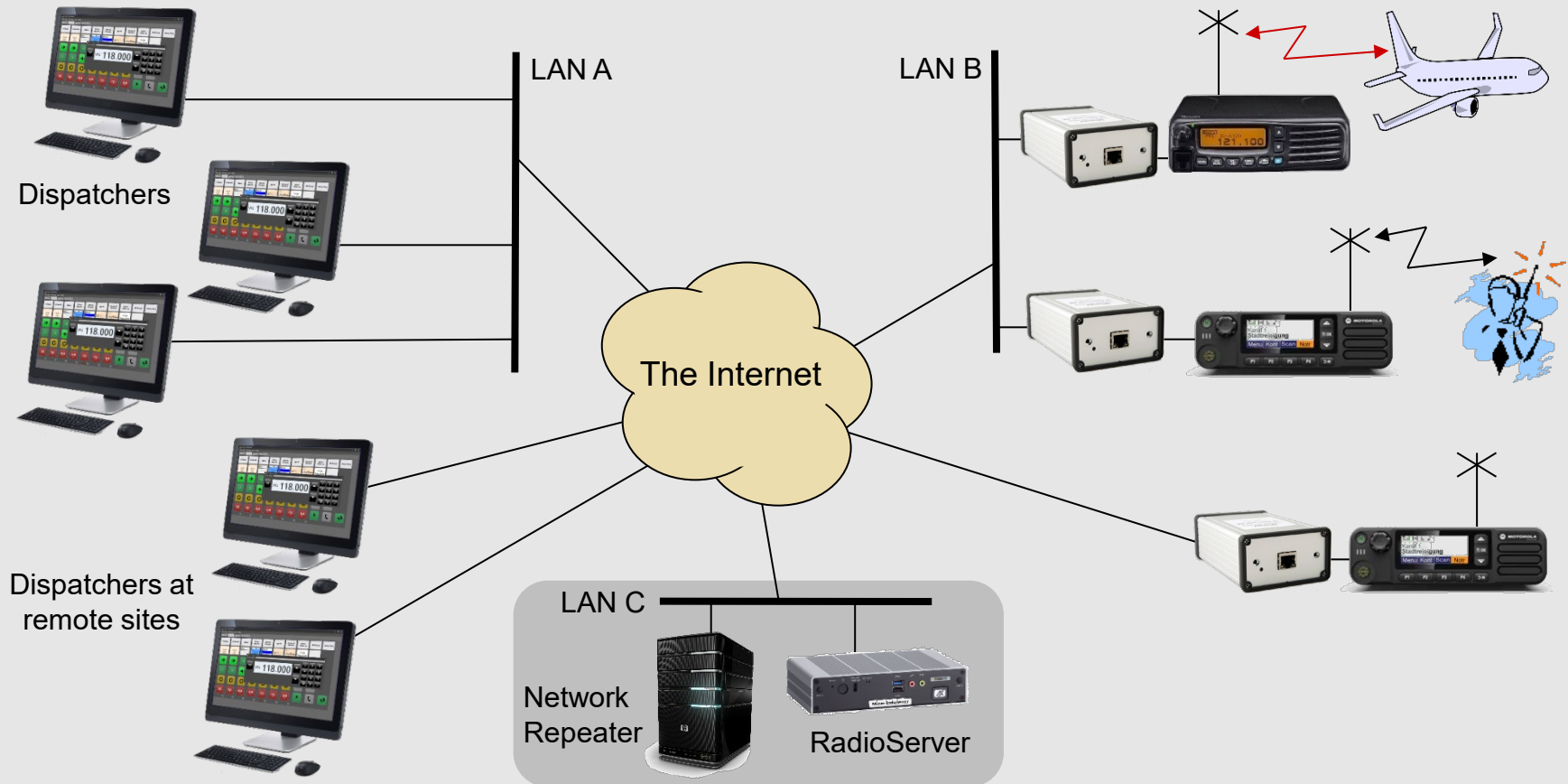

Alternative setup, where the servers are placed in another location. This could be a server hall or similar. The NetworkRepeater connects to all radios and the RadioServer to all Operators, **both using TCP**. Between the servers there are **UDP** in the local LAN.

Remote control from several places of several radios

Alternative setup

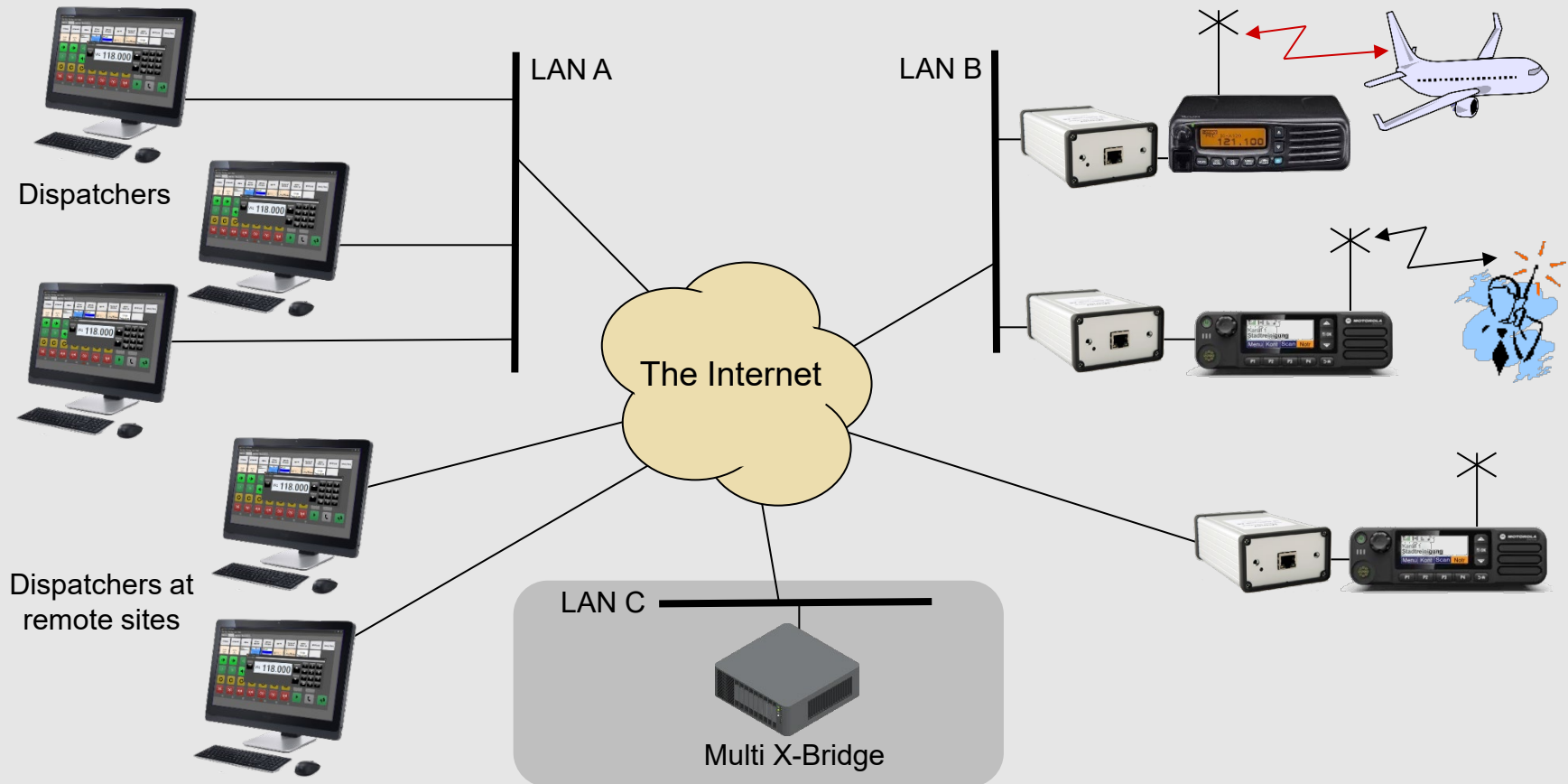

Alternative setup, where the Multi X-Bridge is placed in another location.
This could be a server hall or similar. All connections are **TCP**.

Remote control from several places of several radios

Alternative setup

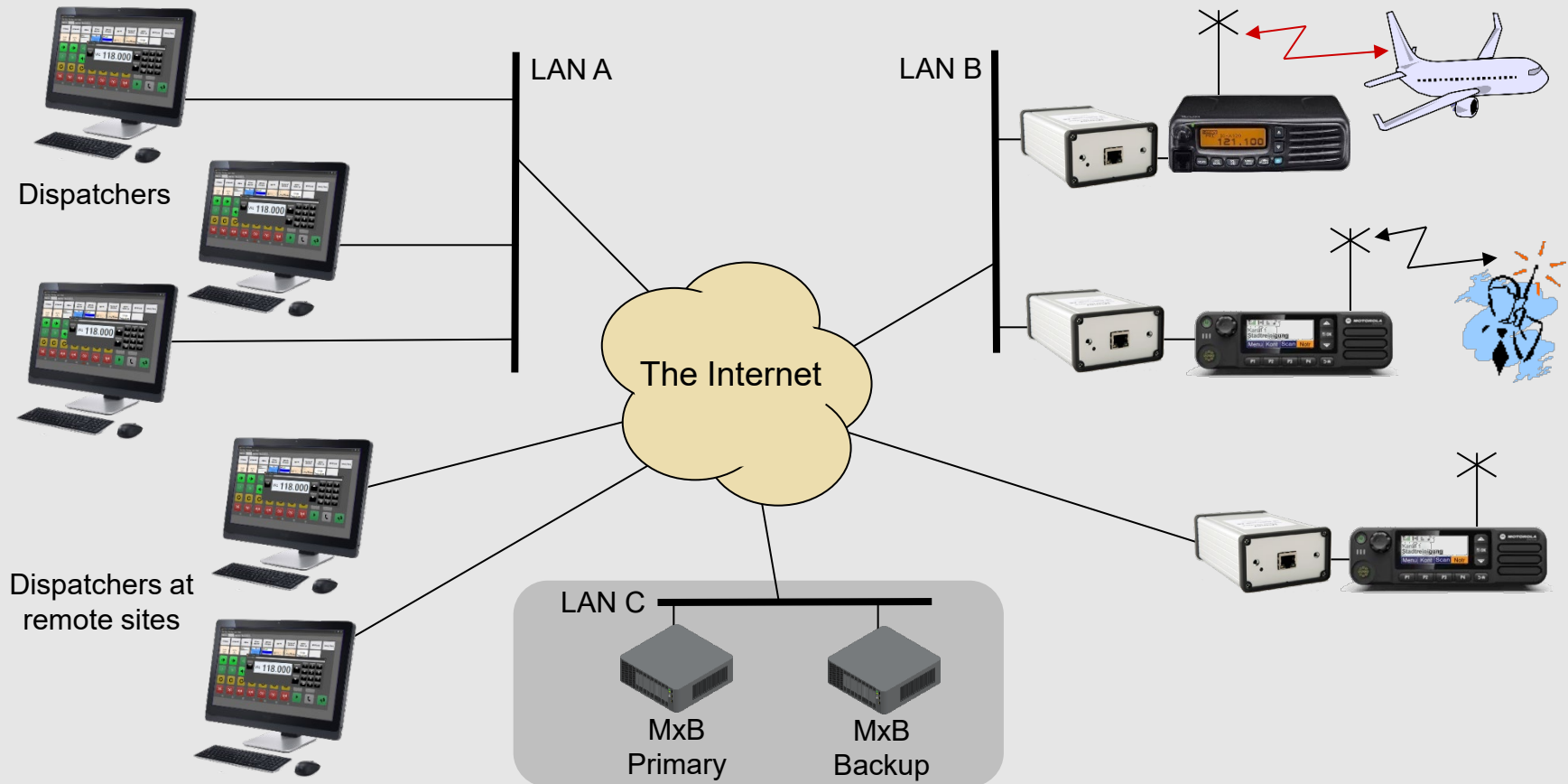

The Multi X-Bridge can be doubled with full hot standby failover.
Connection between the two servers is **UDP**.

Remote control over high orbit satellite

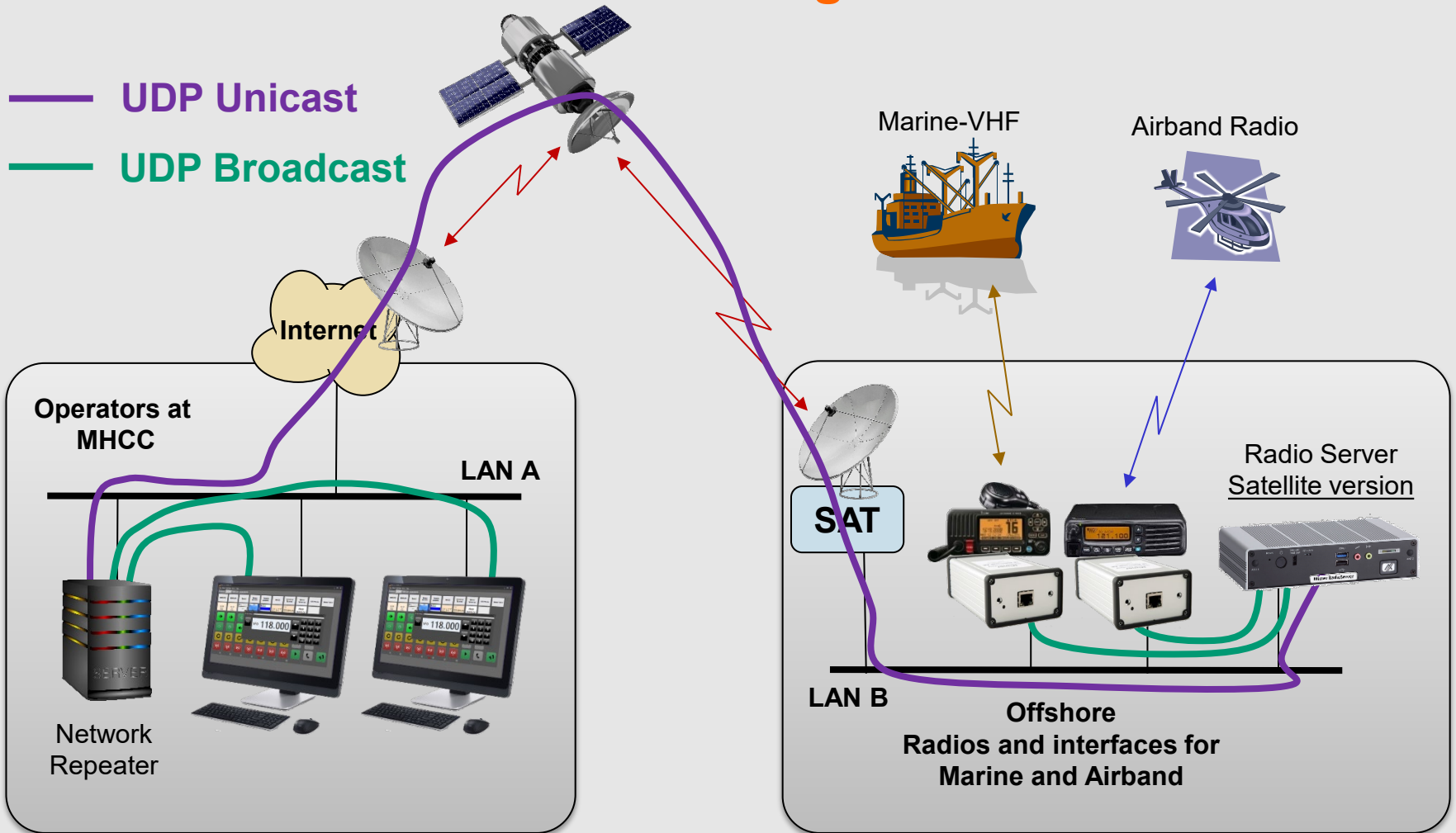

The RadioServer connect to the Network Interfaces via UDP.
The NetworkRepeater connects to the RadioServer using UDP Unicast.
The Dispatchers connect to the NetworkRepeater using UDP.

Mimer RadioServer



The RadioServer is delivered as a ready to run box. It consists of a Linux computer and software. It runs on 12VDC, so that it can be powered from the same source as the radio for redundancy. It will reboot automatically if the power has been out and then been restored.

The RadioServer is also available as Debian package (.deb) for Ubuntu, on a customer preferred server platform.

www.lse.se/radioserver

Mimer NetworkRepeater



The NetworkRepeater is delivered as a Windows software to be run on a Windows computer or server.

Mimer NetworkRepeater LE: Up to 8 devices connected

Mimer NetworkRepeater: Up to 100 devices connected

www.lse.se/networkrepeater

Mimer Multi X-Bridge (MxB)



Mimer MxB is a Linux-based solution designed for flexible deployment. It is distributed as a Debian package (.deb) for Ubuntu.

The MxB can also be delivered in a hot standby configuration.

www.lse.se/mxb